



**IN-WALL[®] SLIDE-OUT SYSTEM
TROUBLESHOOTING GUIDE**

LIPPERT
COMPONENTS[™]

TABLE OF CONTENTS

System Inoperative	3
Controller.....	3
Motors and Harnesses.....	4
Room Stuck Out (Retail)	5
Electronic Manual Override.....	5
Disengage Motors, Manually Retract Room and Travel Lock.....	6
Room Stuck In (Dealer Only)	7
Electronic Manual Override.....	7
Remove Exterior Fascia to Access Motor Retention Screw.....	8
Visual Inspections	9
Measurements.....	9
Floor Rollers.....	10
V-Rollers.....	10
Gear Racks.....	10

System Inoperative

Controller

1. Locate Controller (Fig. 1).
2. Activate switch.
3. Look for the status LEDs on the controller to light while switch is activated (Fig. 1E).
4. If status LEDs light, but no error codes are present, skip to page 9 of this guide to do a visual inspection of the mechanical portions of this system.
5. If status LEDs do not light, and no error codes are present, check the following:
 - A. Check for 12V DC in to controller (red and black terminals) (Fig. 1D).
 - B. Check for 12V DC at switch connection on both extend and retract (Fig. 1C).
 - C. Check the battery for 12V DC.
6. If error codes are present, refer to the label on the controller for error identification.

Fig. 1 - Controller

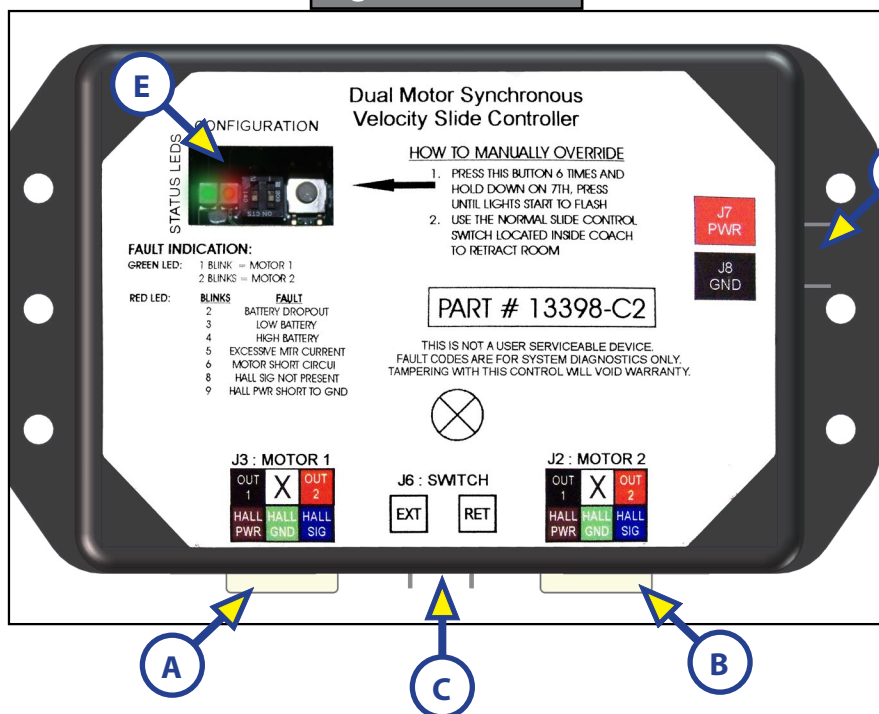

Controller (Fig. 1)	
Callout	Description
A	Motor 1 Junction
B	Motor 2 Junction
C	Switch Junction
D	Power Junction
E	Controller LED Display

Motors and Harnesses

1. Check for proper connections between the motors and harnesses.
2. Visually inspect the exposed harnesses to ensure they are not pinched or damaged.
3. If test harness is available, connect the test harness from the controller to the motor and try to operate the slide-out using the normal switch.
4. If test harness is not available, ohm test the harness.

Fig. 2 - Motor and Harness

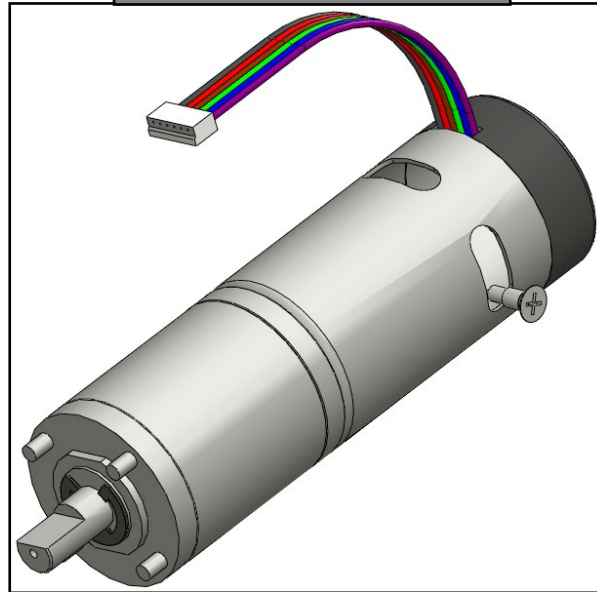

Room Stuck Out (Retail)

Electronic Manual Override

1. Locate the controller.
2. Press the "mode button" six times quickly. Press and hold a seventh time for approximately five seconds (Fig. 3).
3. The red and green LED lights will begin to flash, confirming the override mode.
4. Release mode button.
5. Use the normal slide-out control switch to retract the room.

NOTE: If wall switch is not pushed within 60 seconds of entering the electronic manual override mode, the controller will revert to normal operating mode. No action is required to return to normal operating mode.

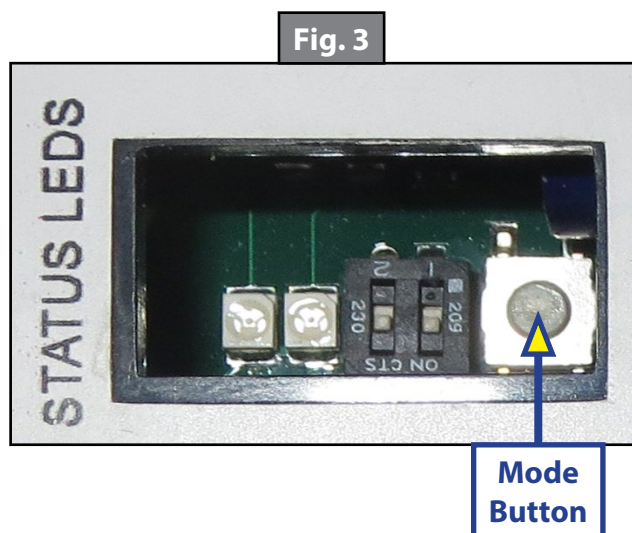

Disengage Motors, Manually Retract Room and Travel Lock

1. Bend back wipe seal. Visually locate motor and motor retention screw. Remove the screw (Figs. 4, 5 and 7).
2. Pull the motor up until disengaged. Replace the motor retention screw to hold the motor in this position (Fig. 6).
3. Repeat this process for both sides of the slide room.
4. Push or pull room back in to the opening while keeping the sides relatively even.
5. The room must be travel locked to keep room in place for road travel.

Fig. 4 - Retention Screw

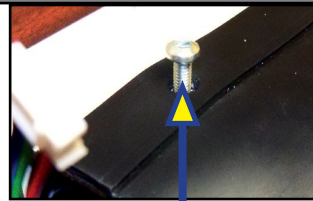

Fig. 5 - Motor



Fig. 6 - Motor

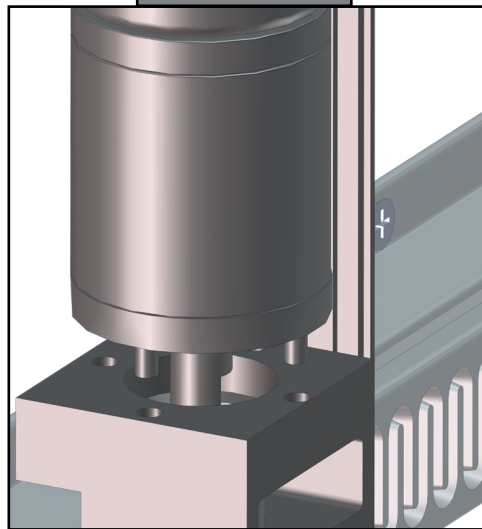
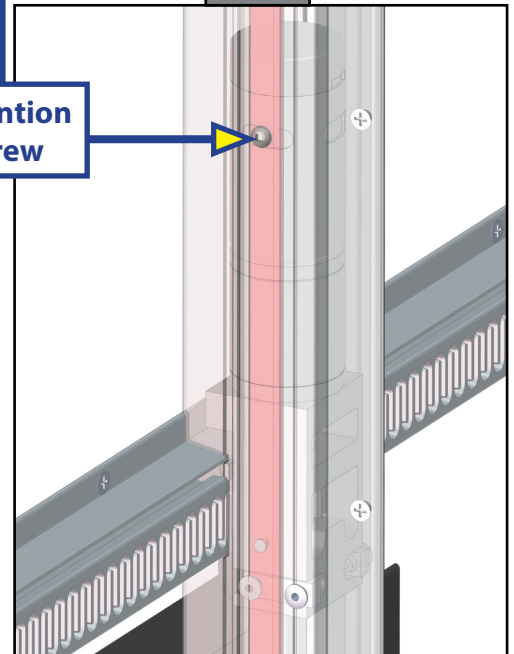

Fig. 7

Retention
Screw



Room Stuck In (Dealer Only)

Electronic Manual Override

1. Locate the controller.
2. Press the "mode button" six times quickly. Press and hold a seventh time for approximately five seconds (Fig. 8).
3. The red and green LED lights will begin to flash, confirming the override mode.
4. Release mode button.
5. Use the normal slide-out control switch to extend the room.

NOTE: If wall switch is not pushed within 60 seconds of entering the electronic manual override mode, the controller will revert to normal operating mode. No action is required to return to normal operating mode.

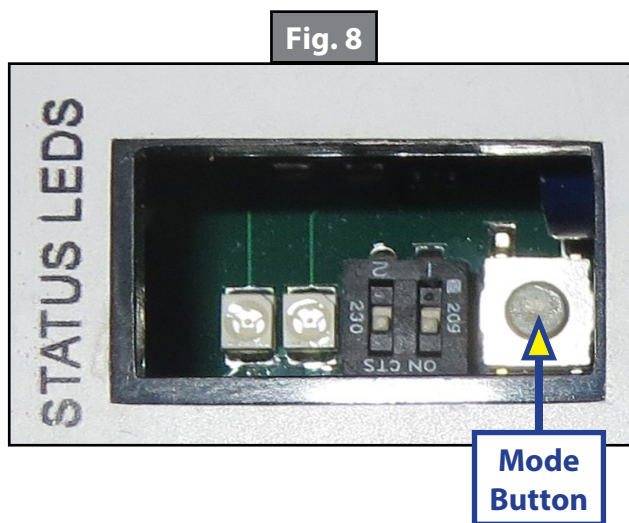

Remove Exterior Fascia to Access Motor Retention Screw

1. Remove exterior fascia carefully so as not to damage it.
2. Locate and remove motor retention screw located near the top of each vertical column (Figs. 9 and 12).
3. Bend back wipe seal and visually locate motor (Fig. 10).
4. Pull the motor up until disengaged. Replace the motor retention screw to hold the motor in this position (Fig. 11).
5. Repeat this process for both sides of the slide room.
6. Push room out of the opening while keeping sides relatively even.

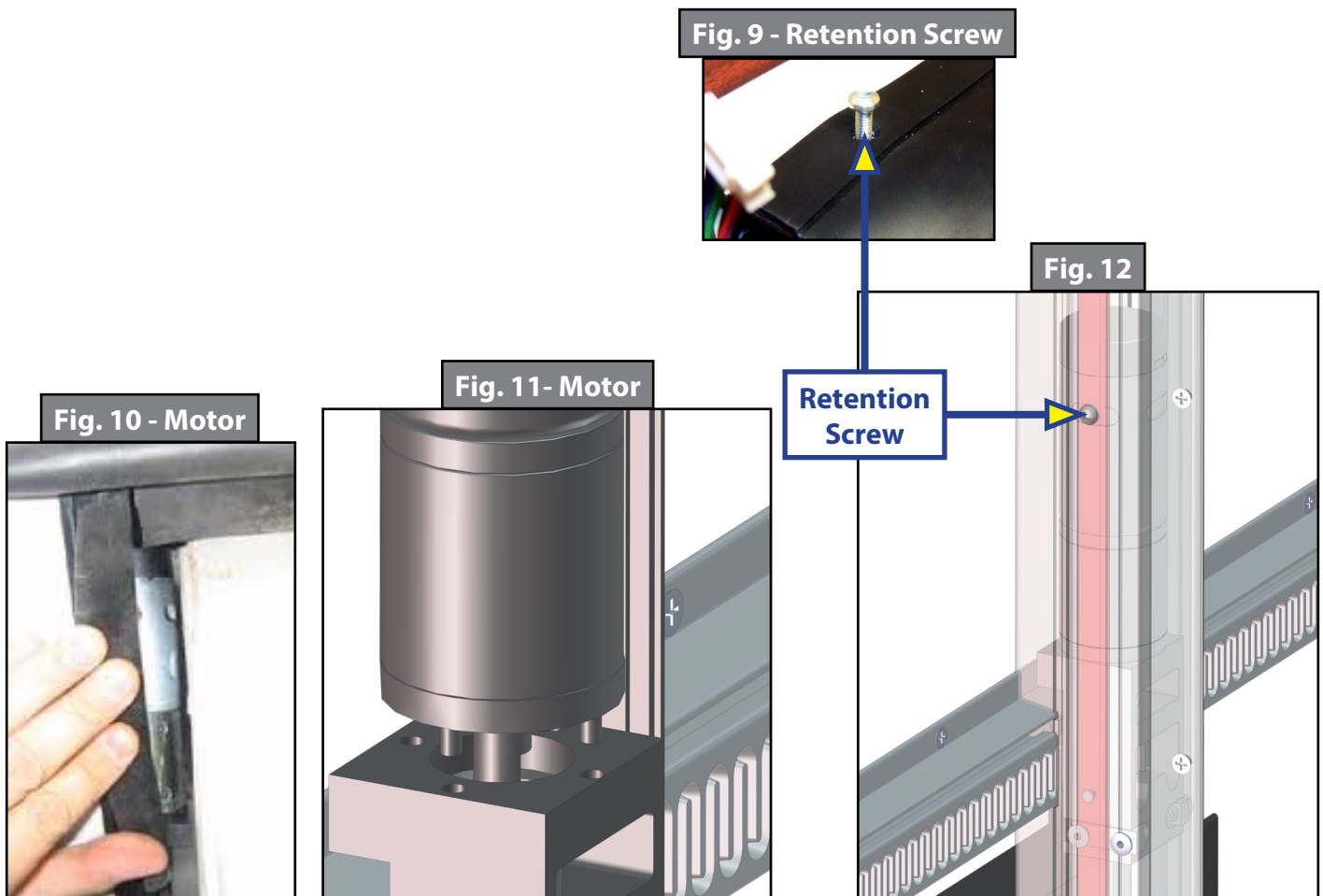

Visual Inspections

Measurements

1. Measure from the outside edge of the column to the face of the gear rack (Fig. 13 and 14). The standard measurement should be 2 ½" plus or minus ⅛". Take this measurement when the room is fully extended and again when the room is 3" from fully retracted.

NOTE: For units with non-standard installations, contact the OEM for their specific measurements.

2. Measure the gear racks for parallel. There should be less than ⅛" difference between the parallel measurements.
3. Check for proper seal engagement (no binding).
4. Check for damage to gear rack.

Fig. 13 - Gear Rack Measurements

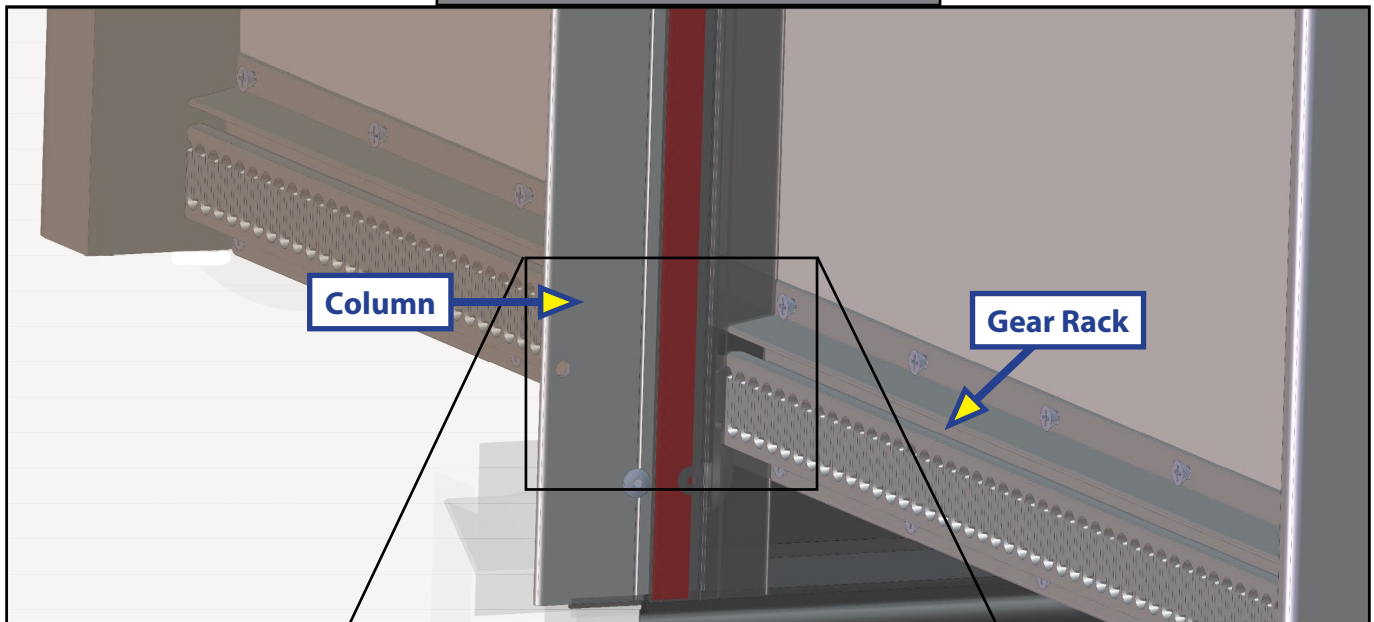
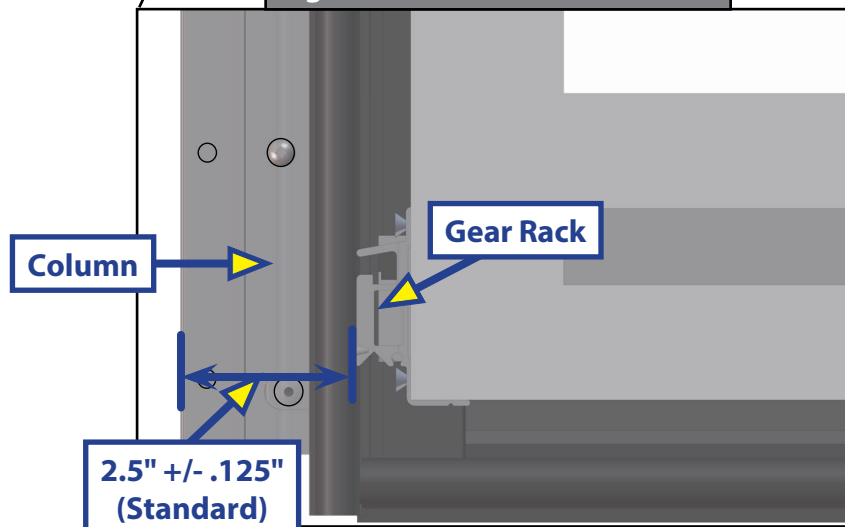
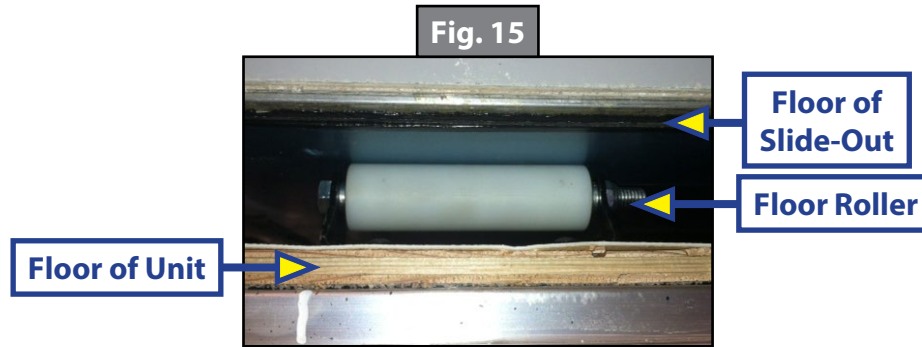

Fig. 14 - Column and Gear Rack



Floor Rollers

1. Check that the seals are not getting caught in the rollers, which could cause binding to the slide-out.
2. Check for proper roller engagement:
 - A. Rollers should not be digging into the floor of the slide-out.
 - B. Rollers should not spin freely beneath slide-out.



V-Rollers

1. Visually inspect V-roller (Fig. 16D) for obstructions or damage.

Gear Racks

1. Check to make sure the screws in the gear rack are secured flush and not getting caught in the seals (Fig. 16B).

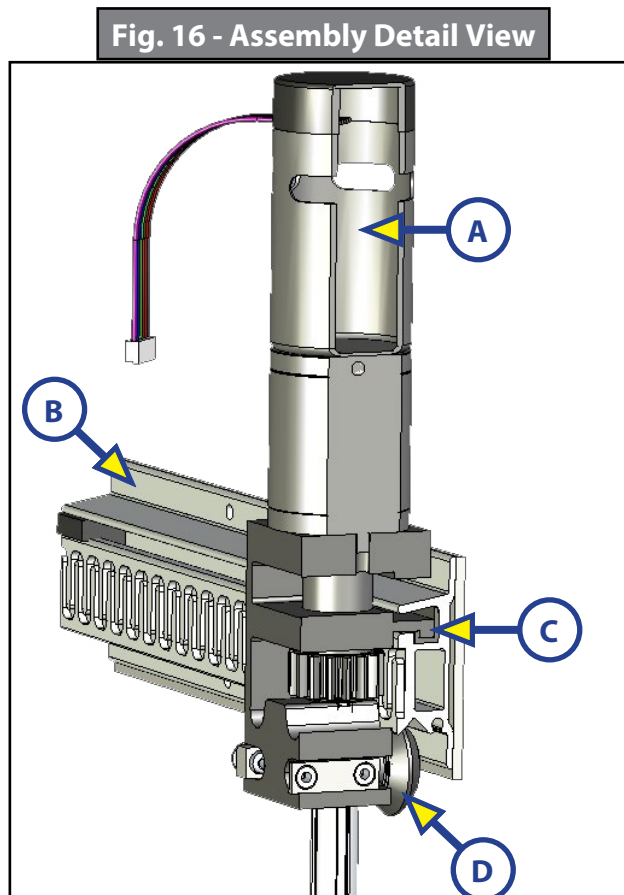

Callout	Description
A	Motor
B	Gear Rack
C	Shoe
D	V-Roller



L I P P E R T C O M P O N E N T S™

The contents of this manual are proprietary and copyright protected by Lippert Components, Inc. ("LCI"). LCI prohibits the copying or dissemination of portions of this manual unless prior written consent from an authorized LCI representative has been provided. Any unauthorized use shall void any applicable warranty. The information contained in this manual is subject to change without notice and at the sole discretion of LCI. Revised editions are available for free download from lci1.com.

Please recycle all obsolete materials.

For all concerns or questions, please contact
Lippert Components, Inc.

Ph: (574) 537-8900 | Web: lci1.com | Email: customerservice@lci1.com